

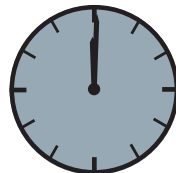

Betrieb der Seilwinde im Fahrbetrieb nicht erlaubt!
 Operation of the winch in driving mode not allowed!
 Fonctionnement du treuil pendant la conduite n'est pas permis!
 Operar el cabrestante mientras se conduce no está permitido!
 Vinssiä ajon ei ole sallittua!
 Obsluha navijáku při jízdě není povoleno!
 Betjene vinsjen under kjøring ikke er tillatt!
 Använda vinsch under körning är inte tillåtet!



MONTAGEANLEITUNG ASSEMBLING INSTRUCTIONS



7 Stunden

weight: ca. 22 kg

WINCH CONSOLE FRONT AND MUDGUARD FOR STEERING LINKAGE / SEILWINDENKONSOLE FRONT UND SCHUTZBLECH FÜR LENKGESTÄNGE

- Artikel-Nr: 19R 5080

Wild Land Drivers GmbH
 Sportplatzstr. 4
 D-85635 Höhenkirchen b.München

E-Mail: info@wild-land-drivers.de
 Phone: +49 (0) 8 10 2 / 89 58-16

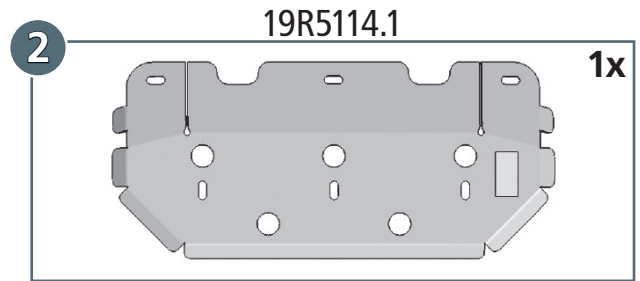
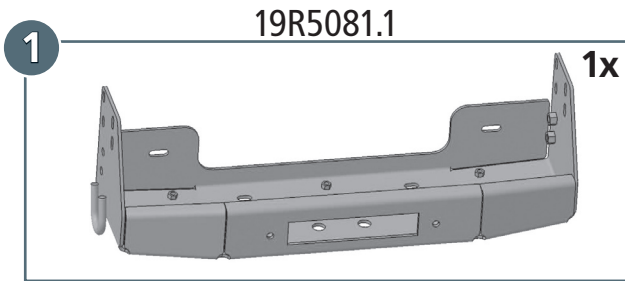

mounting kit: 19R9080

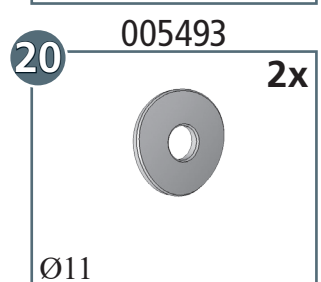
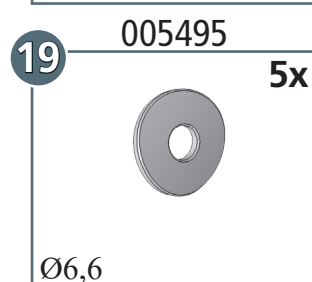
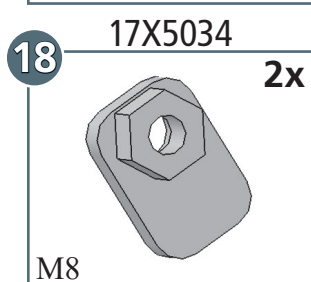
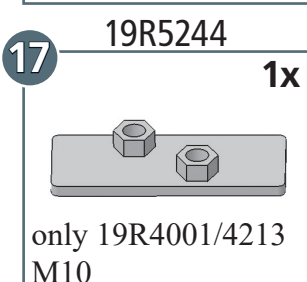
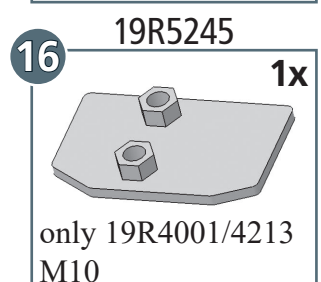
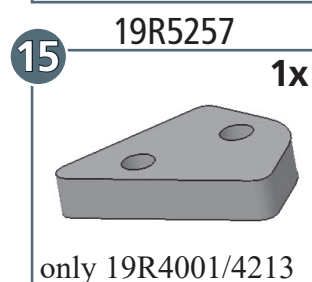
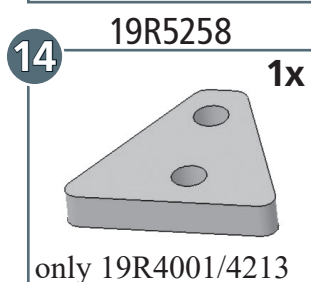
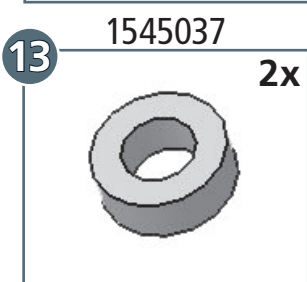
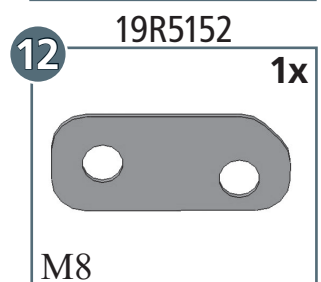
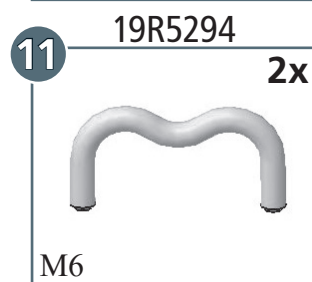
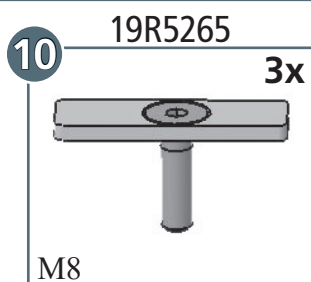
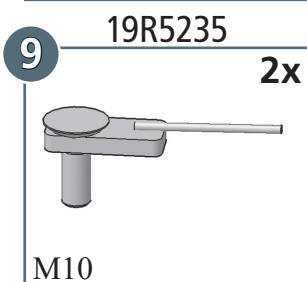
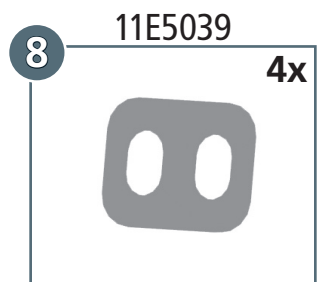
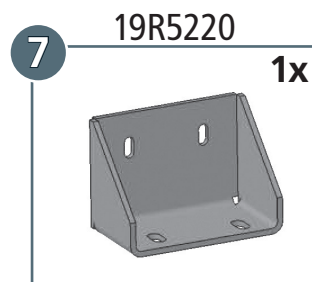
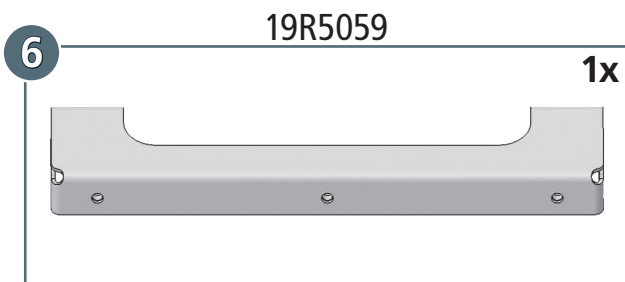
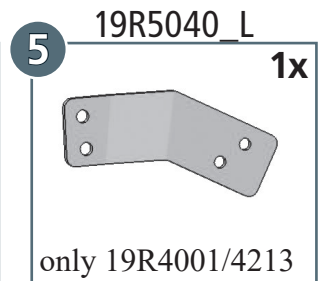
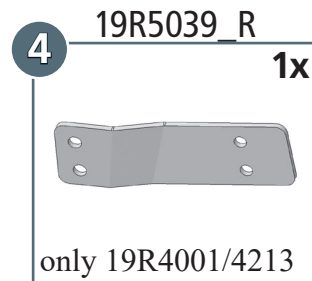
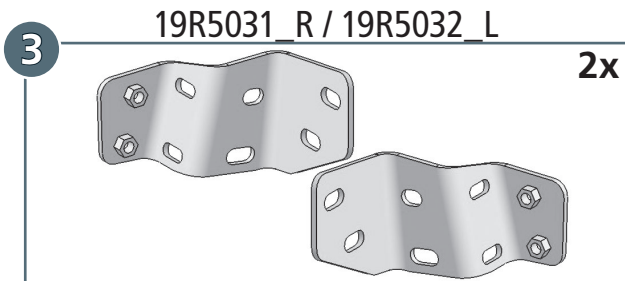



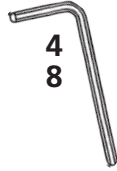







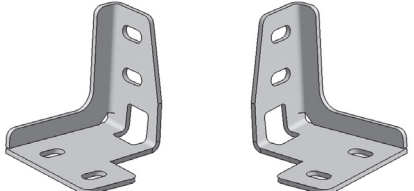
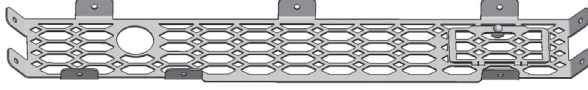
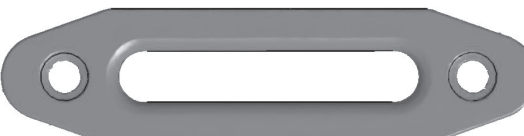
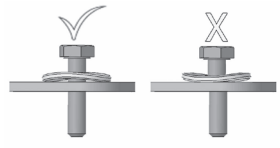

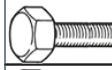
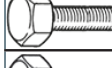
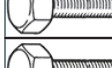
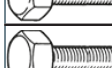
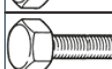
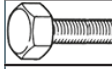
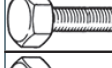
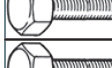
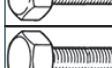
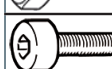



M6:
10 Nm
M6 (A2):
8,8 Nm
M8:
25 Nm
M8(A2):
21,4 Nm
M10:
50 Nm
M12:
87 Nm



Kompatibel mit 19R4001, 19R4201 + 19R4213
Compatible with 19R4001, 19R4201 + 19R4213
Compatible avec 19R4001, 19R4201 + 19R4213

mounting kit: 19R9080

<p>21 005497 17x</p>  <p>Ø9</p>	<p>22 1745167 1x</p>  <p>D7</p>
<p>23 19R5140 R / 19R5141 L 2x</p>  <p>only 19R4201</p>	
<p>24 19R4725 1x</p> 	
<p>25 1x</p>  <p>not included!</p>	
	

	M6x16; DIN 933 Zn	2x
	M6x25; DIN 933 Zn	1x
	M6x70; DIN 933 Zn	2x
	M8x20; DIN 933 Zn	6x
	M8x25; DIN 933 Zn	6x
	M8x70; DIN 933 Zn	2x
	M10x35; DIN 933 Zn	4x
	M10x45; DIN 933 Zn	2x
	M10x50; DIN 933 Zn	2x
	M10x55; DIN 933 Zn	2x
	M12x30; DIN 933 Zn	4x
	M10x30; DIN 912 Zn	2x
	M6x16; ähnl. ISO 7380 A2	10x
	M6; DIN 934 A2	10x
	M6; DIN 934 Zn	8x
	M8; DIN 934 Zn	5x
	M10; DIN 934 Zn	6x
	Ø8,4; DIN 125 Zn	2x
	Ø10,5; DIN 125 Zn	7x
	Ø13; DIN 125 Zn	4x
	Ø6,4; DIN 9021 A2	10x
	Ø6,4; DIN 9021 Zn	6x
	Ø10,5; DIN 9021 Zn	4x

Artikel-Nr:
19R5080

Revision 6: 06.03.2024



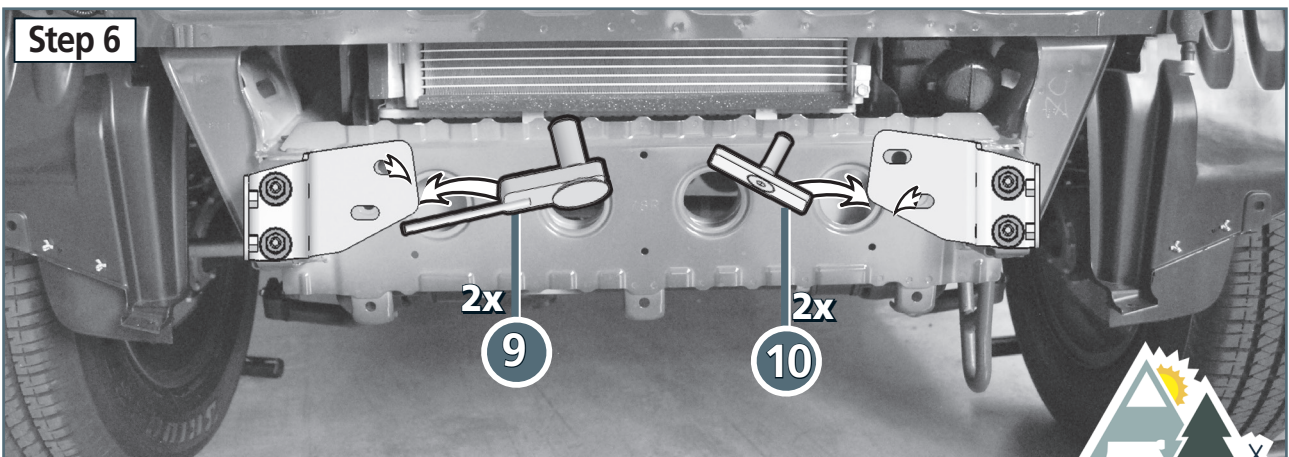
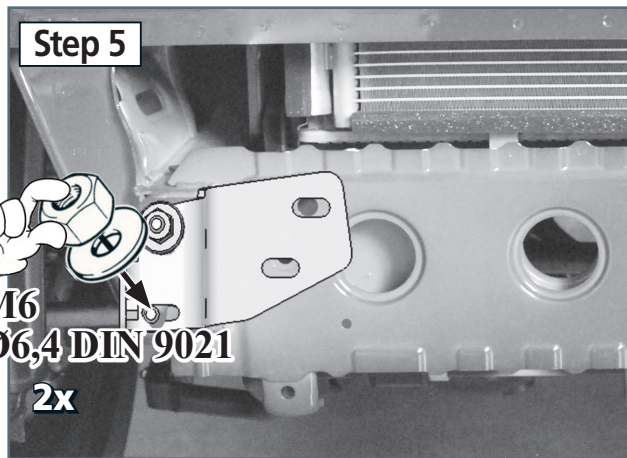
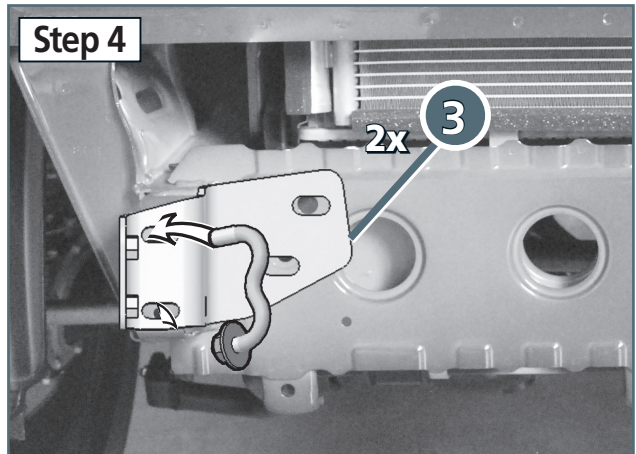
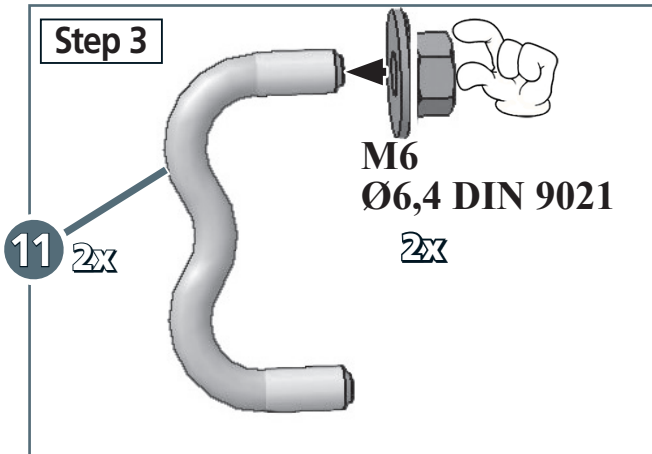
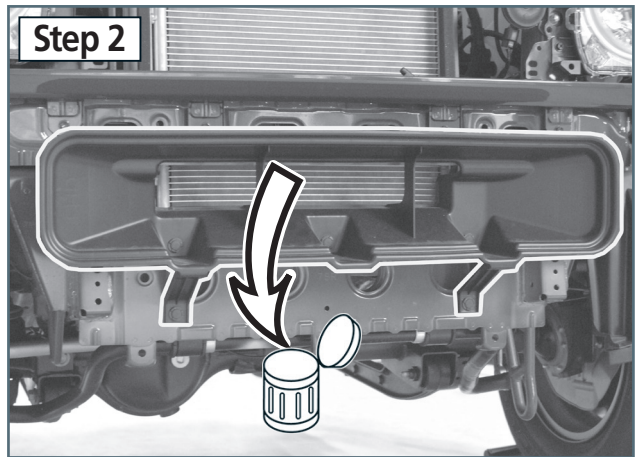
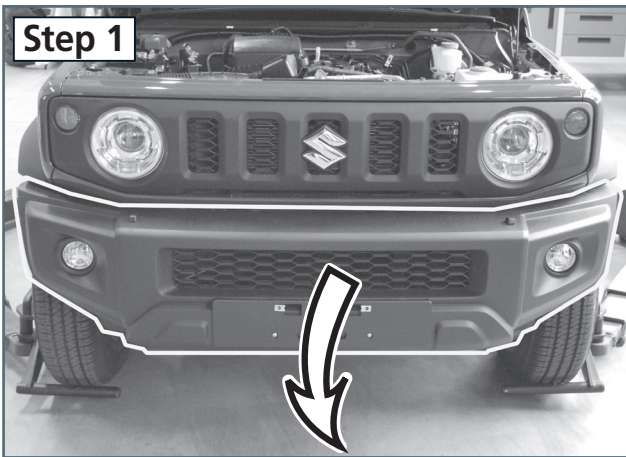

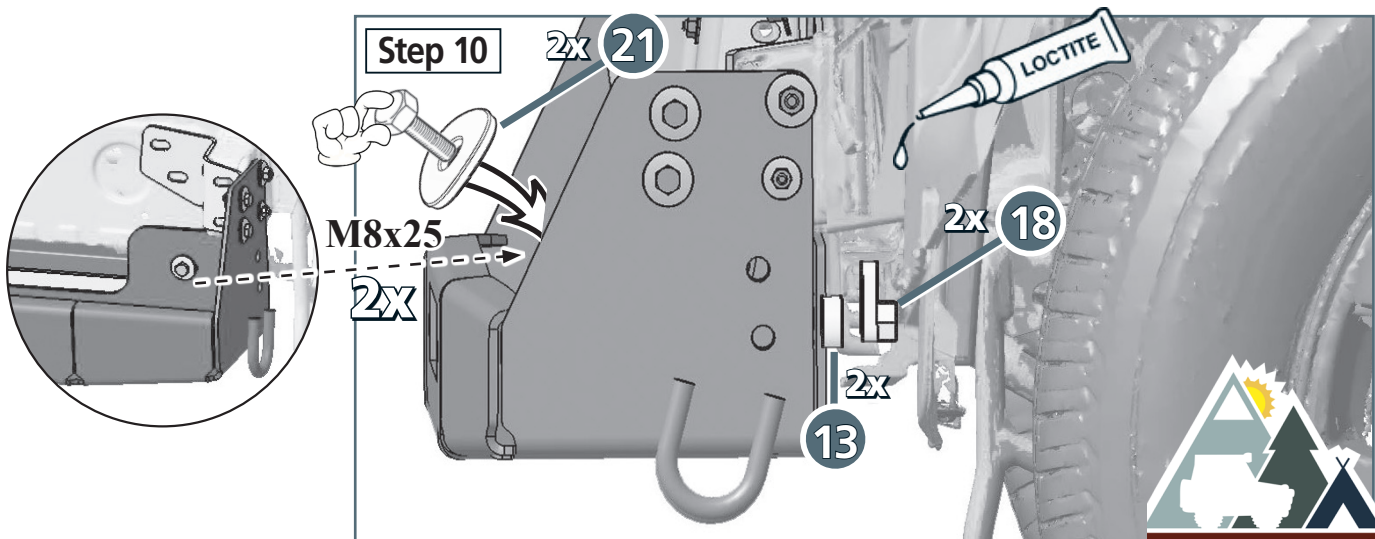
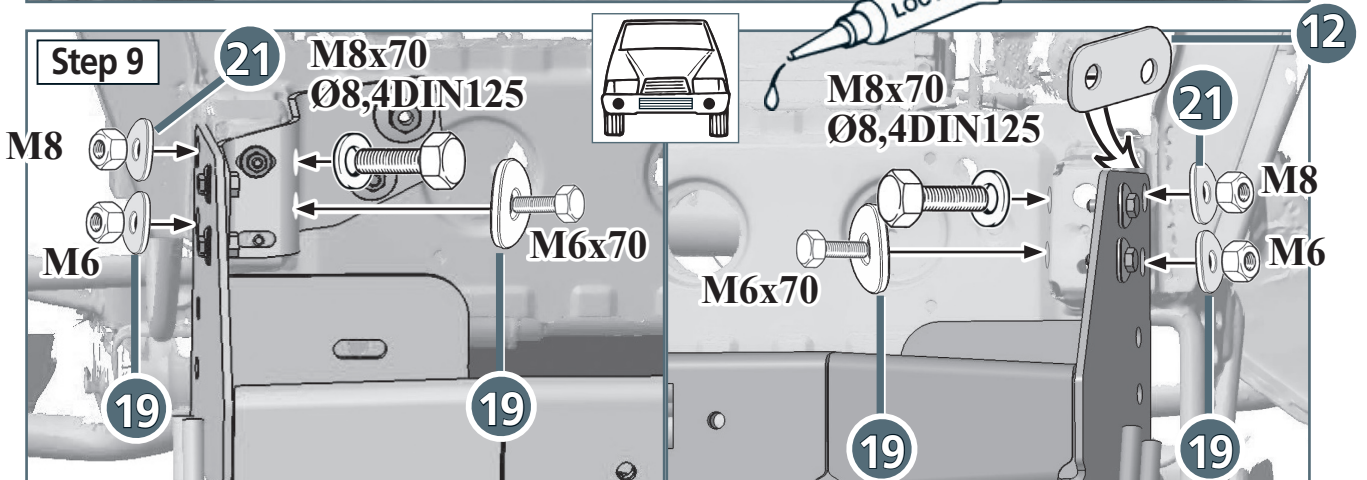
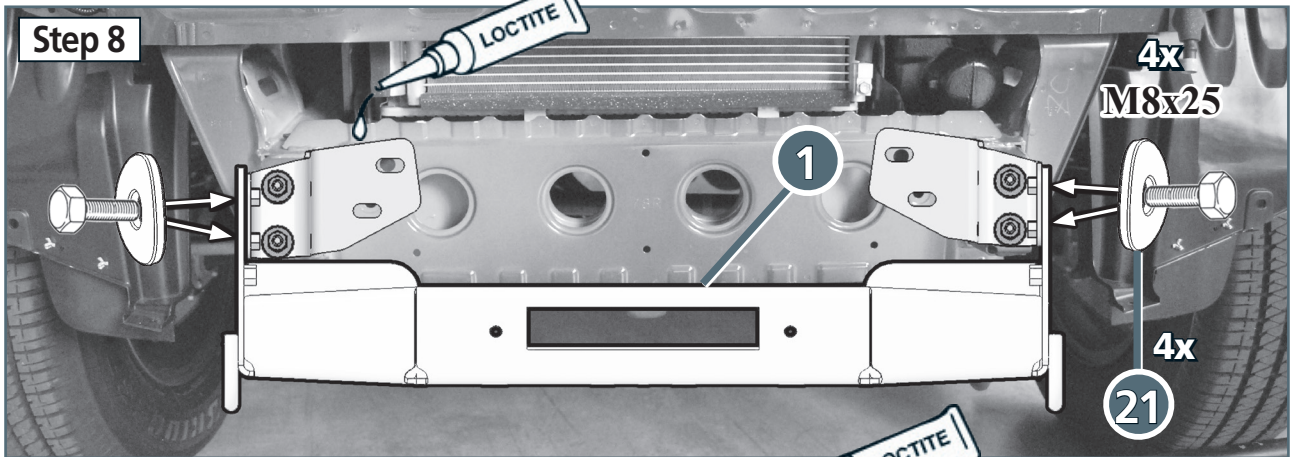
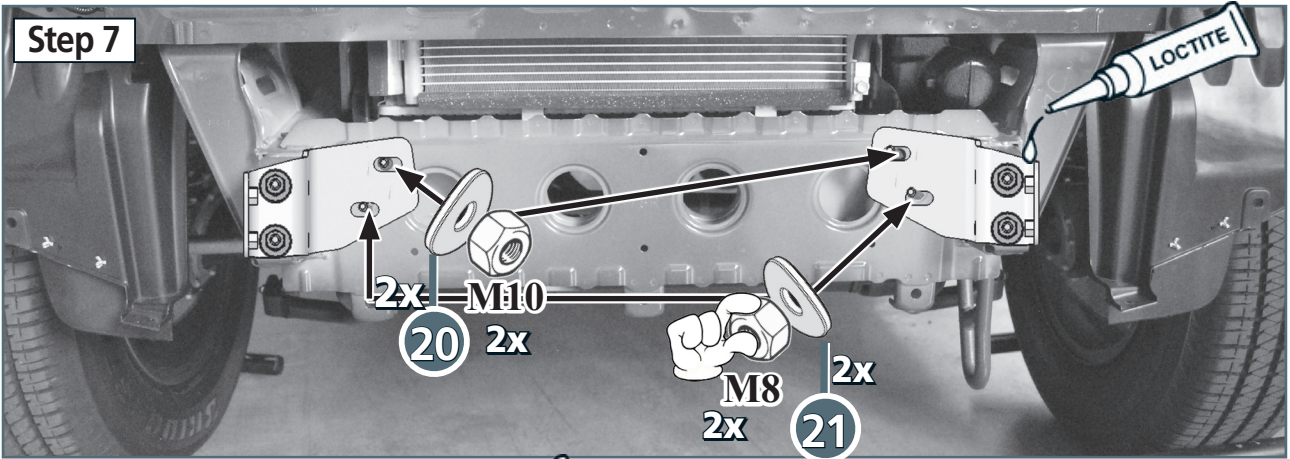

only for 19R4001 and 19R4213!

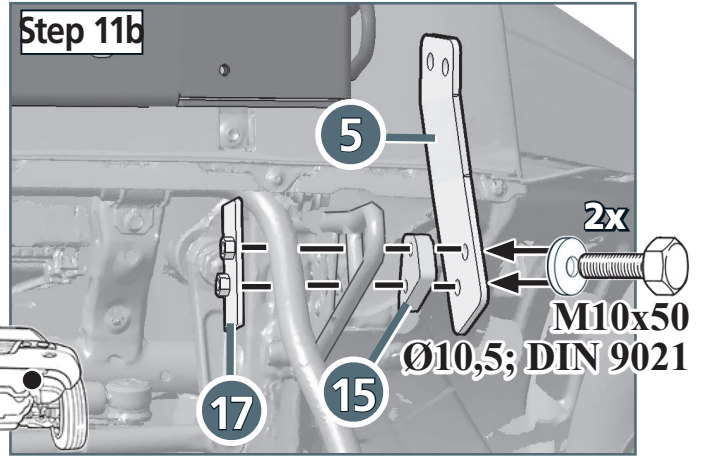
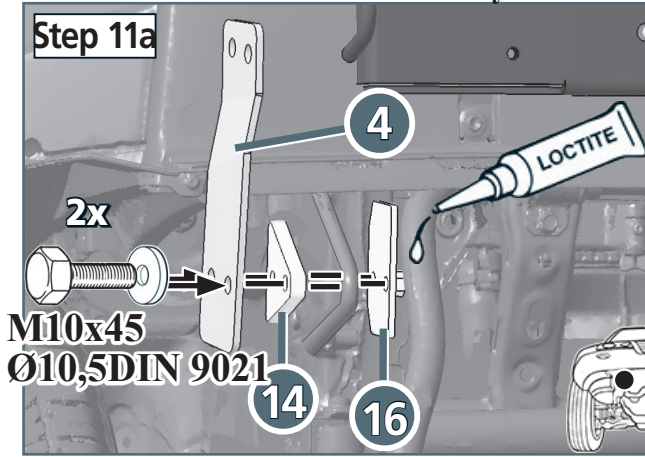

only for 19R4001 and 19R4213!

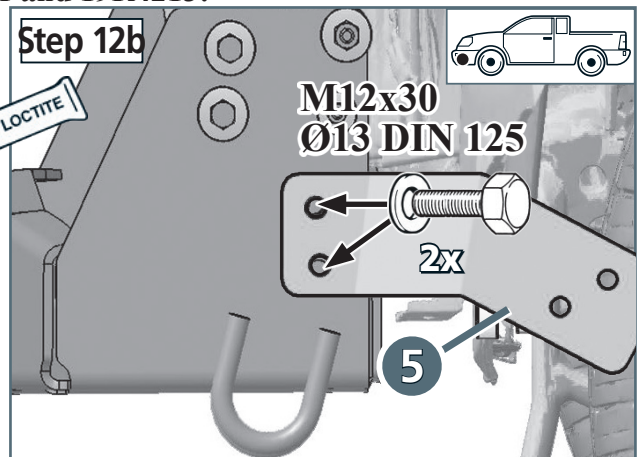
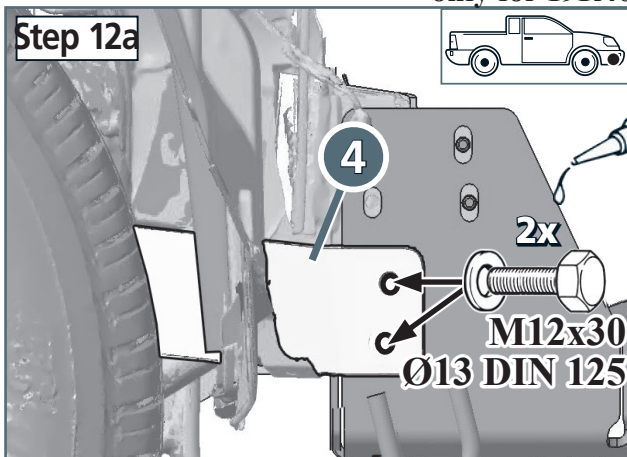

only for 19R4201!

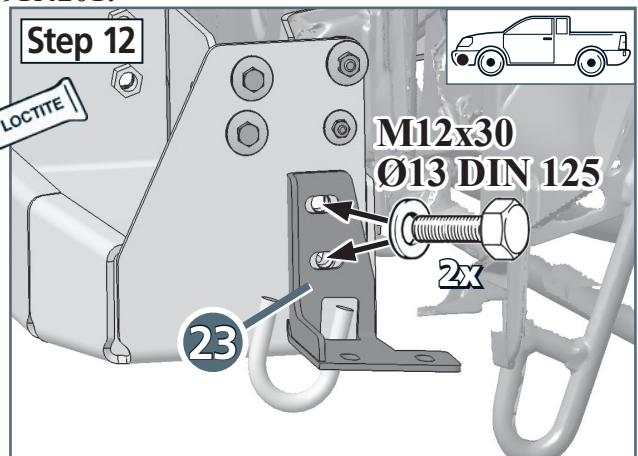
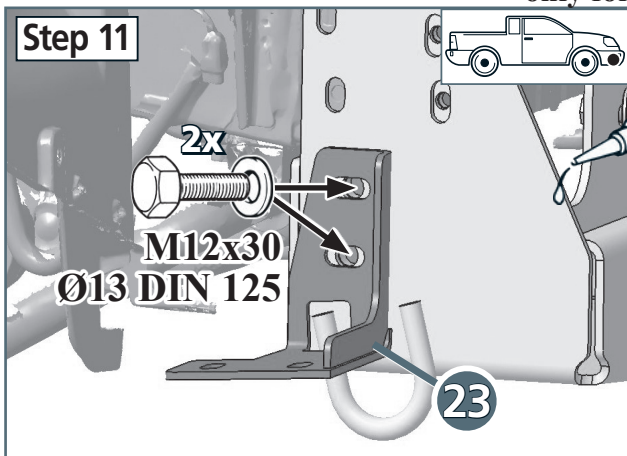

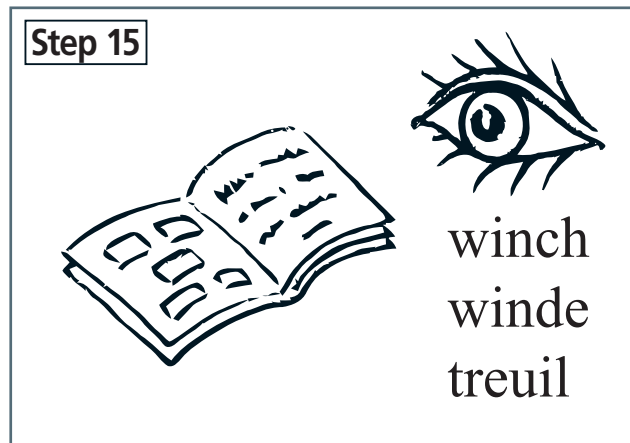
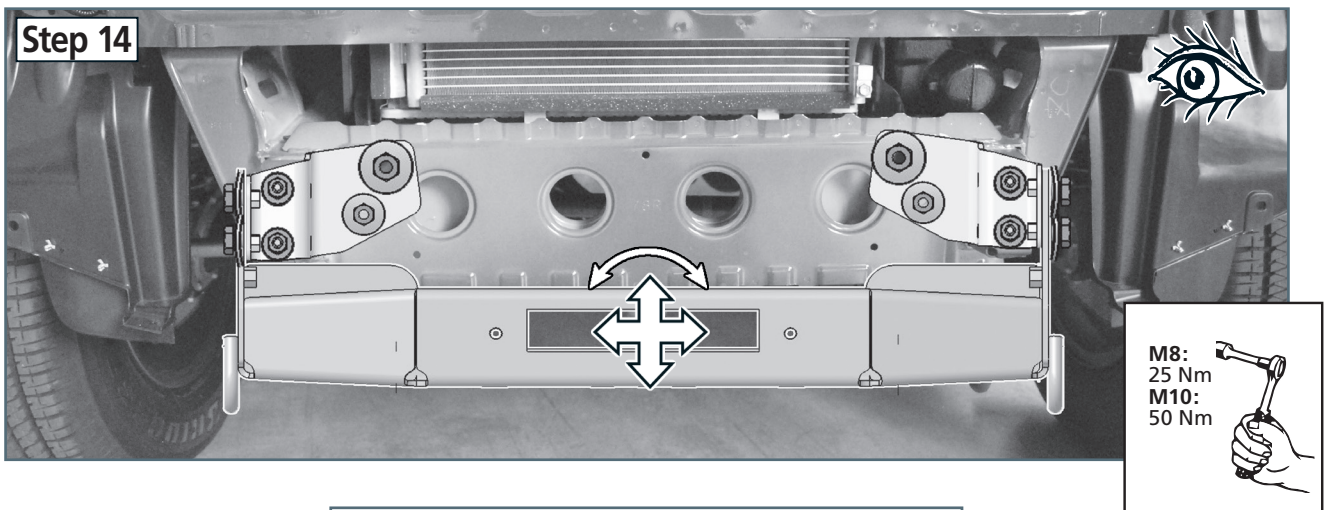
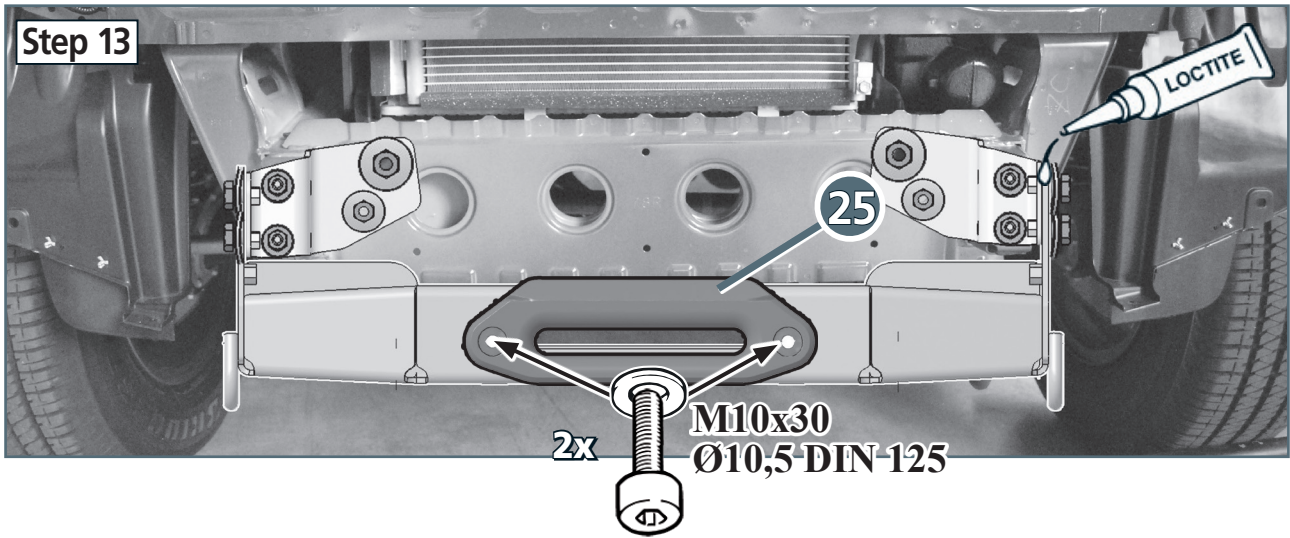

come up

